

ECR #: 32

Title: Low Profile NLX Form Factor

Release Date: May 12, 1997

Impact: Change

Spec Version: A.G.P. 1.0

Summary:

Add an NLX form factor for A.G.P. to allow use of A.G.P. in an NLX chassis. This is a low profile form factor that will fit in an NLX chassis and will be compatible with an ATX chassis through the use of a altered bracket.

Background:

The A.G.P. interface specification requires modifications for an NLX A.G.P. card form factor. The drawings and text listed here are intended to show the requirements for the new NLX form factor A.G.P. add-in card. The two most significant changes in the current card form factor are the height of the card and the rear card cutout. The decrease in add-in card height is to accommodate the component height restrictions as specified in the NLX specification. The backside card notch is to allow the card to clear the NLX stacked I/O connectors in the back of the chassis.

Change Current Specification as shown:

Update current specification with a new section for NLX implementation. Add the following text to this section:

5.5.X NLX Planar Implementation

The NLX form factor A.G.P.-enabled card is intended for use either an NLX or ATX chassis with an appropriate back panel retaining bracket. The form factor for the NLX A.G.P.-enabled card is depicted in figure X.1. The mechanical aspects of the card are depicted in figure X.2.

The NLX form factor A.G.P.-enabled card has a newly defined retaining bracket to be used with an NLX system. The bracket and chassis interface are shown in figures X.3 and X.4. When this card is used in an ATX chassis, a bracket much like a standard PCI/ISA retaining bracket must be used. The currently defined ATX form factor A.G.P.-enabled add-in card is not compatible with the NLX specification.

I/O connector space on an NLX form factor A.G.P.-enabled card is limited due to the notch in the I/O end of the card as shown in figure X.2. Provisions have been made in the NLX A.G.P.-enabled card form factor to allow for I/O connectors on both the primary and secondary side of the A.G.P.-enabled card. The secondary side implementation must use the spacing defined in figure X.3 such that the connectors on the secondary side of the card extend to the back panel of the chassis. The secondary side implementation is defined so that the slot to slot connector spacing is consistent with current ATX back-panel add-in card implementations. This allows the A.G.P. NLX form factor card to be used in both ATX and NLX by use of an appropriate I/O back panel, even with the secondary side connectors in place. A retention bracket layout concept is shown in figure X.4. It should be noted that a half length NLX A.G.P. card is .100" shorter than the half length ATX A.G.P. card.

Full length NLX A.G.P. form factor cards may use a front end retention bracket as shown in figure X.5. The keepout zones for the NLX A.G.P. form factor card are shown in figure X.6.

Add the following mechanical drawings to the specification:

- Figure X.1 shows a comprehensive view of NLX A.G.P-Enabled add-in card, retention brackets, and chassis interface.
- Figure X.2 shows the assembly view of the I/O bracket and chassis interface for an NLX A.G.P-Enabled add-in card.
- Figure X.3 shows a reference chassis interface bracket for the rear end of an NLX A.G.P-Enabled add-in card.
- Figure X.4 shows a detailed view of an NLX A.G.P-Enabled add-in card I/O bracket with VGA connector location specified, and reference dimensions for potential adjacent connector placement.
- Figure X.5 Shows a detailed view of a front end extender bracket for full length NLX A.G.P-Enabled add-in card.
- Figure X.6 shows a detailed view of the NLX A.G.P-Enabled add-in card with keepouts and height restrictions.

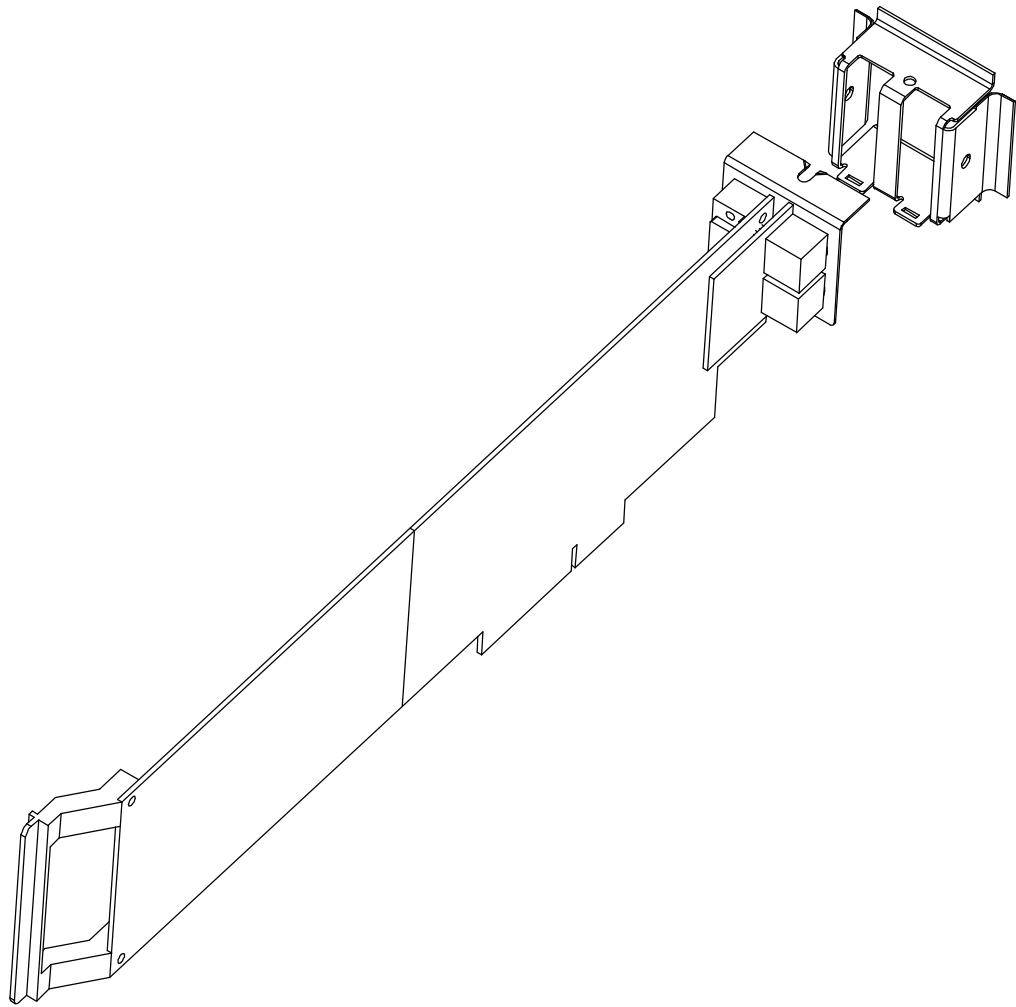

Figure X.1 NLX A.G.P.-Enabled Add-in Card Comprehensive view

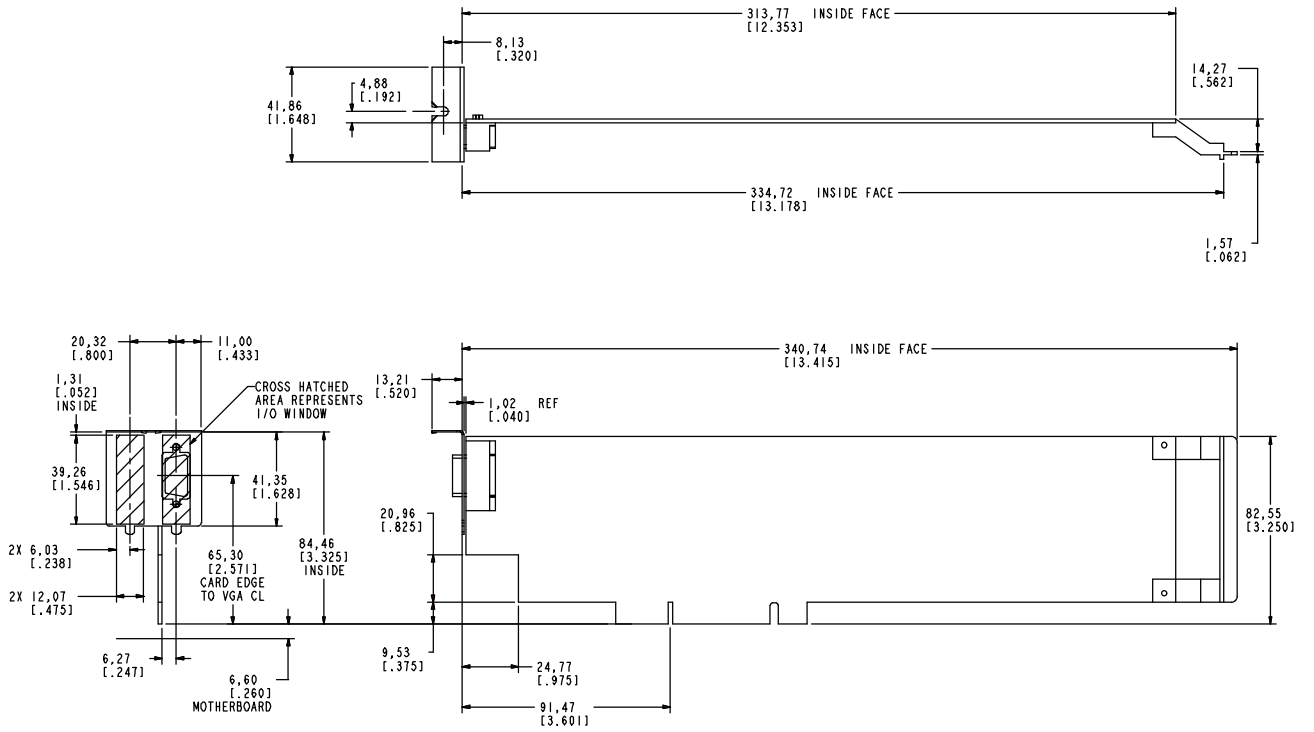

Figure X.2: NLX A.G.P.-Enabled Add-in Card Assembly View

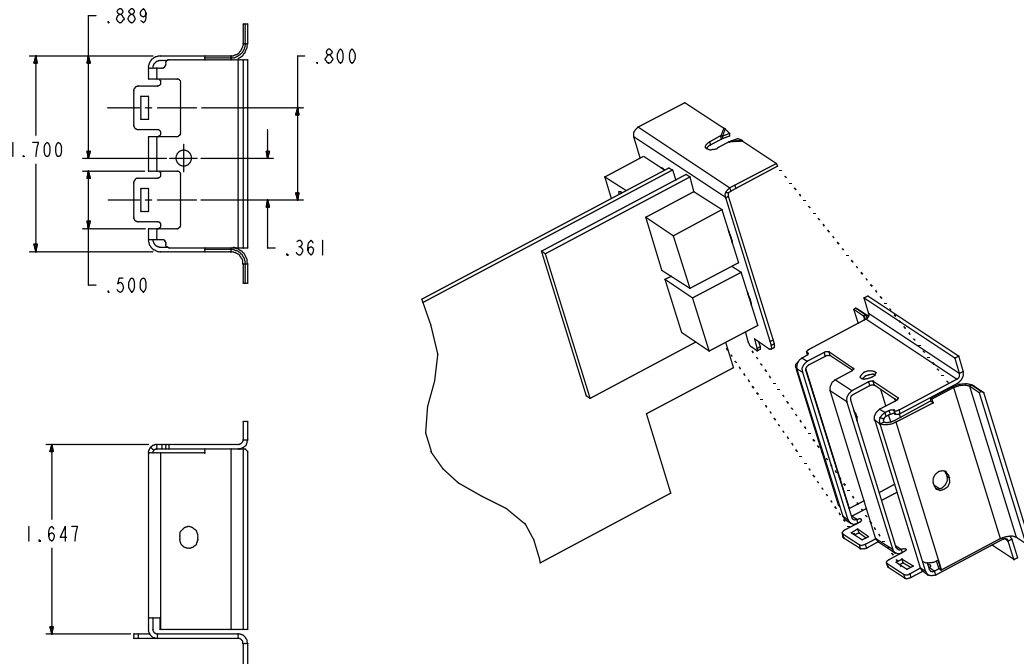

Figure X.3 NLX A.G.P.-Enabled Add-in Card Reference I/O Bracket and Chassis Back Panel Interaction

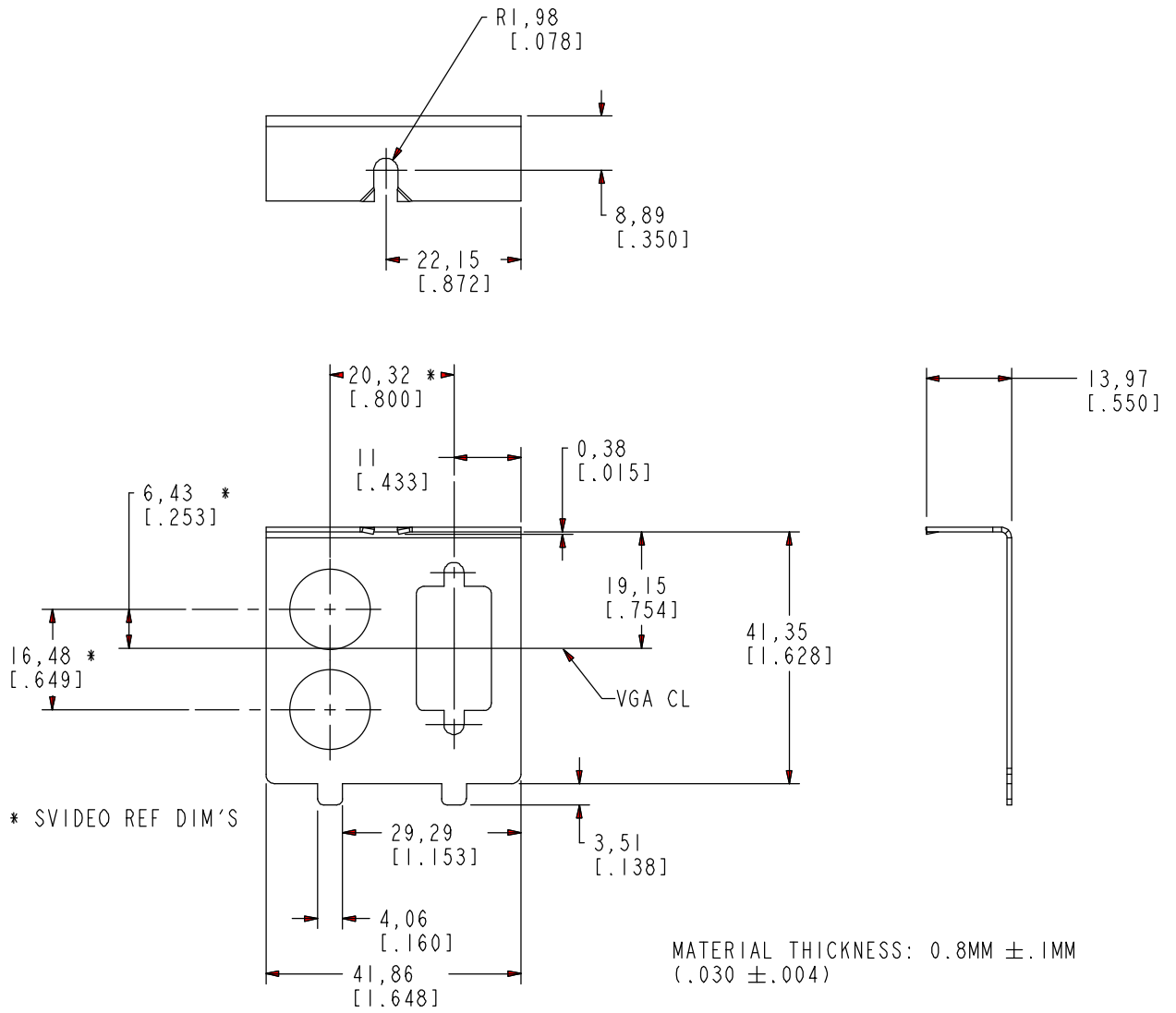

Figure X.4 NLX A.G.P-Enabled Add-in Card I/O Bracket Example Connector Layout

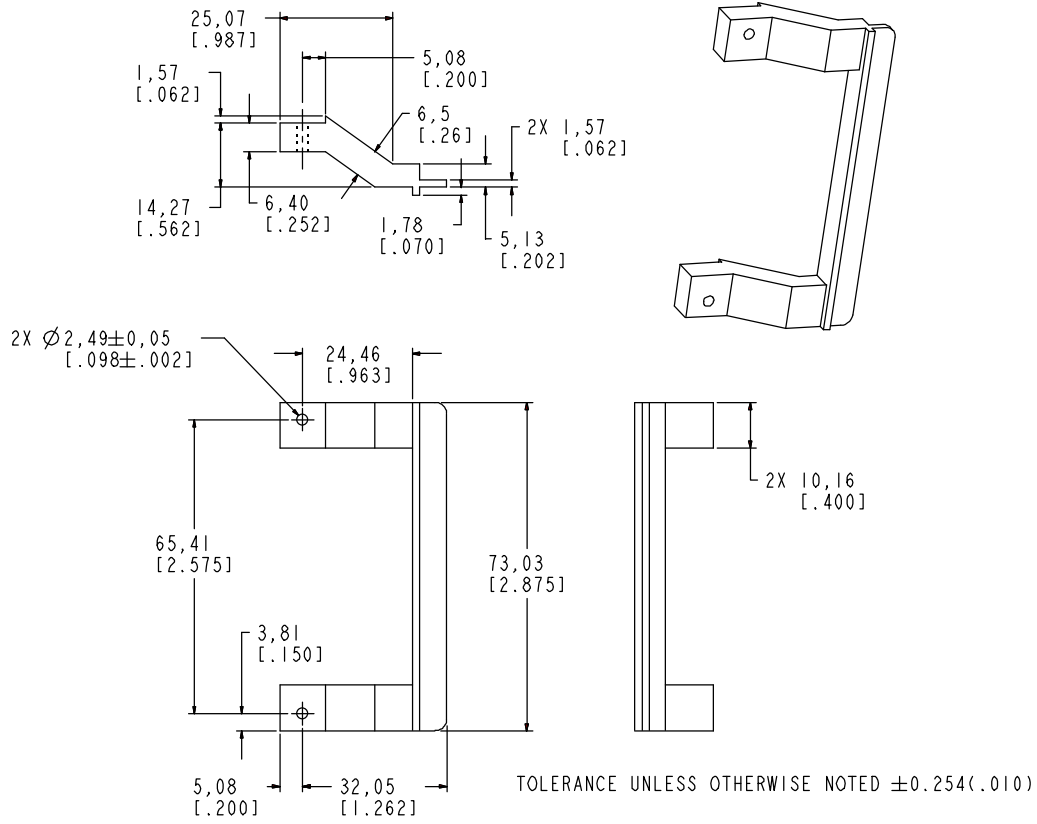
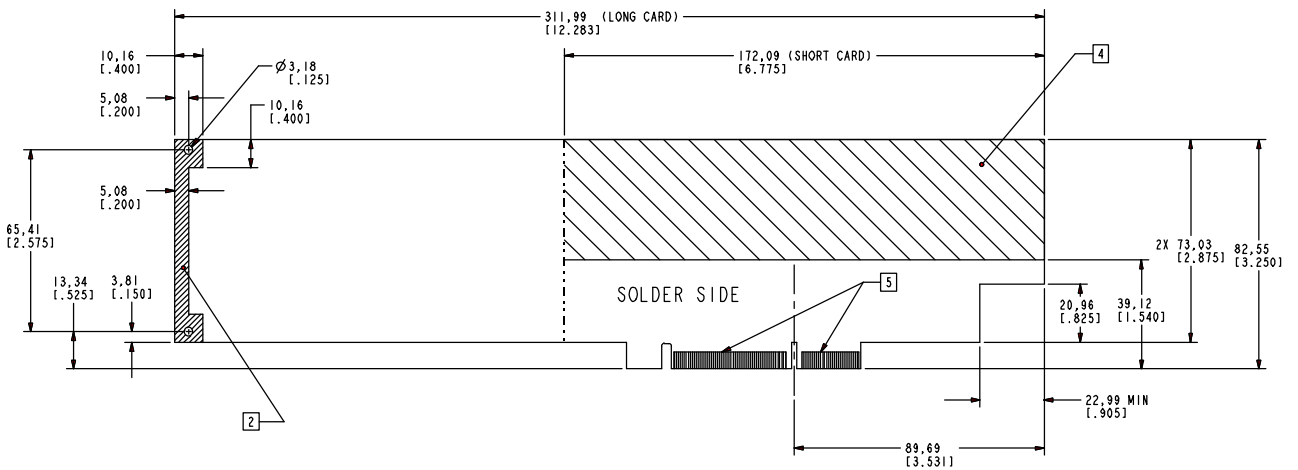

Figure X.5 NLX A.G.P-Enabled Add-in Card Front End Extender for Full Length Cards



NOTES:

- 1. TOLERANCES ±.127 [±.005]
- 2. THIS AREA TO BE COMPONENT FREE BOTH SIDES
- 3. MAXIMUM ALLOWABLE HEIGHT ON SOLDER SIDE IS 2.67[.105] UNLESS OTHERWISE SPECIFIED.
- 4. COMPONENTS IN THIS AREA RESTRICTED TO 22.35[.880]
- 5. GOLD FINGERS SAME AS DETAILED IN THE ATX DESIGN SPECIFICATION, DETAILS A AND B

Figure X.6 NLX A.G.P-Enabled Add-in Card Keepout Zones

